

# POWDER COAT PAINT SYSTEM

**AVAILABLE IMMEDIATELY**

- REYNOSA, MEXICO



15910 Ventura Blvd., Suite 1410  
Encino, CA 91436  
(818) 788-2260  
[sales@machinerynetwork.com](mailto:sales@machinerynetwork.com)

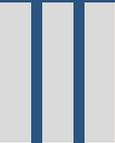

# Introduction

- THE FINISHING LINE WAS BUILT IN 1991 AND UPDATED IN 1997 TO MEET THE PROPRIETARY FINISHING NEEDS FOR METALS IN THE JUVENILE PRODUCT INDUSTRY, THE FITNESS PRODUCT INDUSTRY, AS WELL AS PROVIDE PAINT SERVICES TO VARIOUS PRODUCTION FACILITIES WITHIN THE MAQUILADORA INDUSTRY

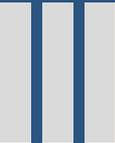

# MAJOR SYSTEM COMPONENTS

- VARIABLE SPEED OVERHEAD CONVEYOR SYSTEM
- 7 STAGE STAINLESS SPRAY WASH SYSTEM
- DRY & CURE OVENS
- MOTORIZED ON/OFF LINE ELECTROSTATIC POWDER APPLICATION SYSTEM

# ADDITIONAL MAJOR SYSTEM COMPONENTS



REVERSE OSMOSIS  
WATER TREATMENT  
SYSTEM



WATER TREATMENT  
SYSTEM



INDIVIDUAL  
SUPPORT  
EQUIPMENT



# VARIABLE SPEED CONVEYOR

- MULTIPLE DRIVE MOTORS
- 1500' PLUS CONVEYOR LENGTH
- TURN WHEELS
- TAKE UP TENSIONER



## 7 STAGE STAINLESS WASHER

- 7 Stage stainless steel tanks w/weirs.
- 2 tanks w/stainless steel heat exchangers
- Polypropylene upper w/stainless joints
- CPVC risers w/quick release nozzles & drain caps



Risers w/quick  
change  
nozzles &  
cleanout caps

## Steam System (heat tanks)

- Boiler #1 Cleavor Brooks 250 HP
- Boiler #2 Cleavor Brooks 150 HP
- Stainless Heat Exchange Plates



# Dry Off and Cure Ovens

- Dry Oven
  - Maxon 4.7 MBH Burner
  - Recirculating blower 15 HP
  - Firye Flame-Safe guard control



- 
- Bake Oven
    - Maxon 6 MBH Burner
    - Recirculating blower 30 HP
    - Firye Flame-Safe guard control
-



## Paint Application

- \*FULLY AUTOMATIC BOOTH
- \*MANUAL BOOTH UP TO 6 GUNS
- \*MOTORIZED GEAR DRIVE FOR OFFLINE/  
ONLINE POSITION
-

# Paint Equipment



STAINLESS STEEL  
POWDER BOOTHS



MINI-CYLONE  
POWDER  
RECOVERY SYSTEM



UV FIRE  
DETECTION  
SYSTEM



ELECTROSTATIC  
AUTOMATIC AND  
MANUAL GUNS



EQUIPMENT  
MANUALS ENGLISH  
& SPANISH

# Automatic Paint Guns

- RECIPROCATING ARMS

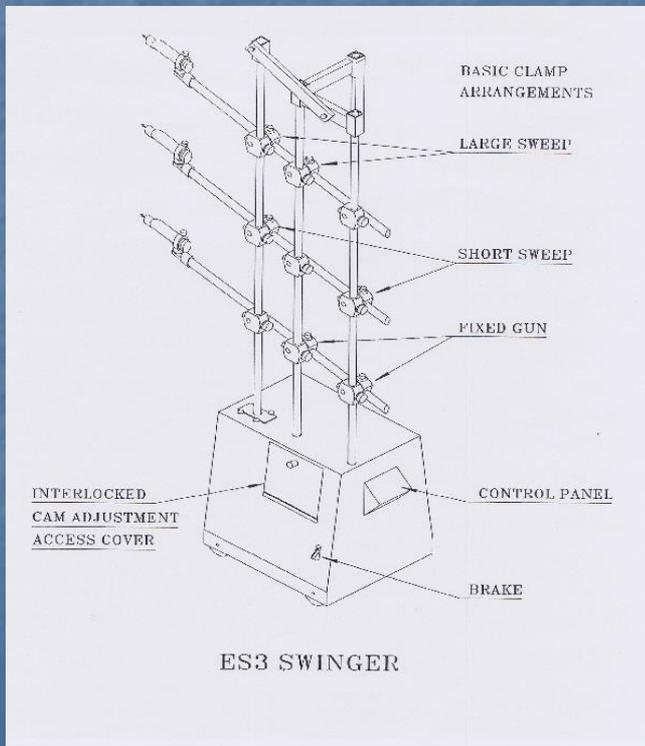

- INDIVIDUAL GUN CONTROL

# Manual Paint Guns

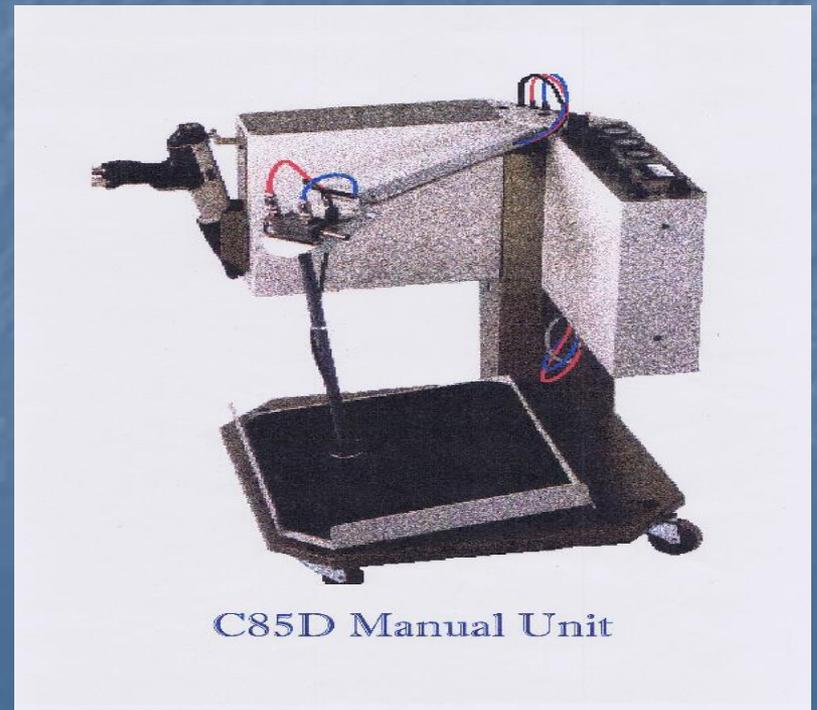
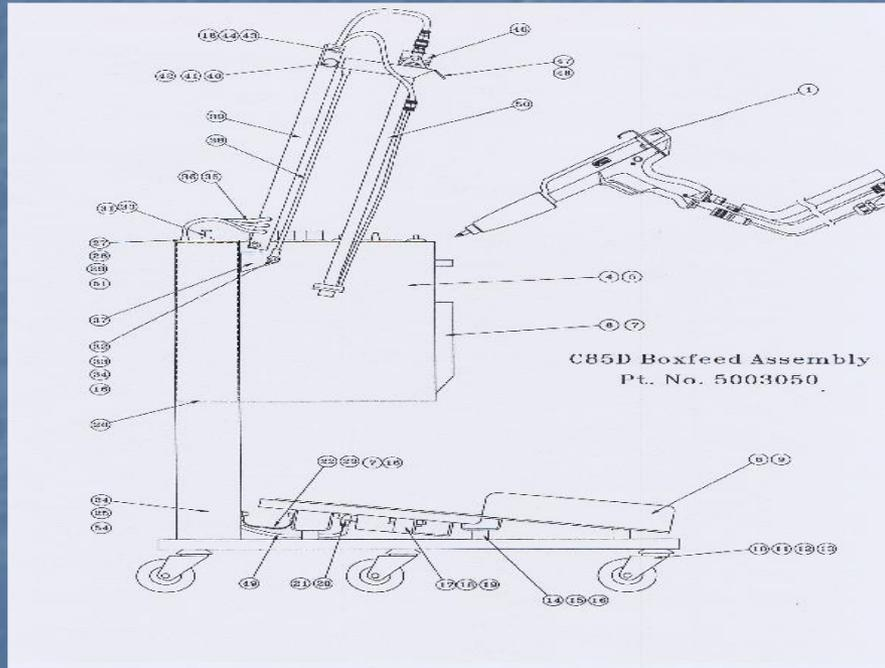

# Motorized Platform

- KEY SWITCH FORWARD/REVERSE
- SMOOTH ELECTRIC OPERATION
- GEAR DRIVE
- QUICK EXCHANGE OF BOOTHS FOR RAPID COLOR CHANGES

# Air Compressor & Filter Drier

- Air Compressor
- Gardner Denver Filter/Drier

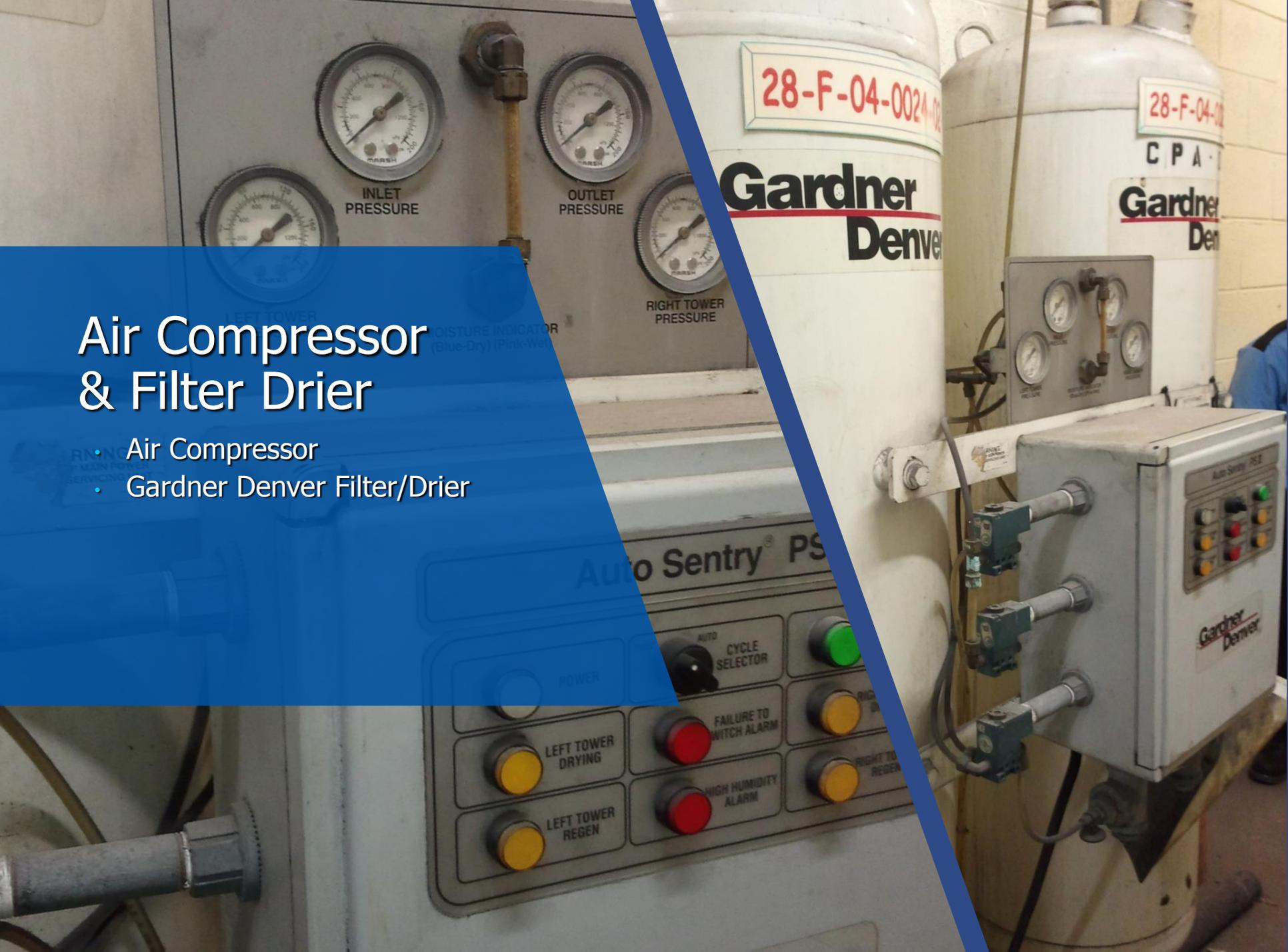



## Reverse Osmosis System

- TOSHIBA EX14B  
PROGRAMMABLE  
CONTROLLER
- GOULDS PUMPS  
COMPANY MODEL SSV
- ROTEC MEMBRANES

# WATER TREATMENT DESIGN

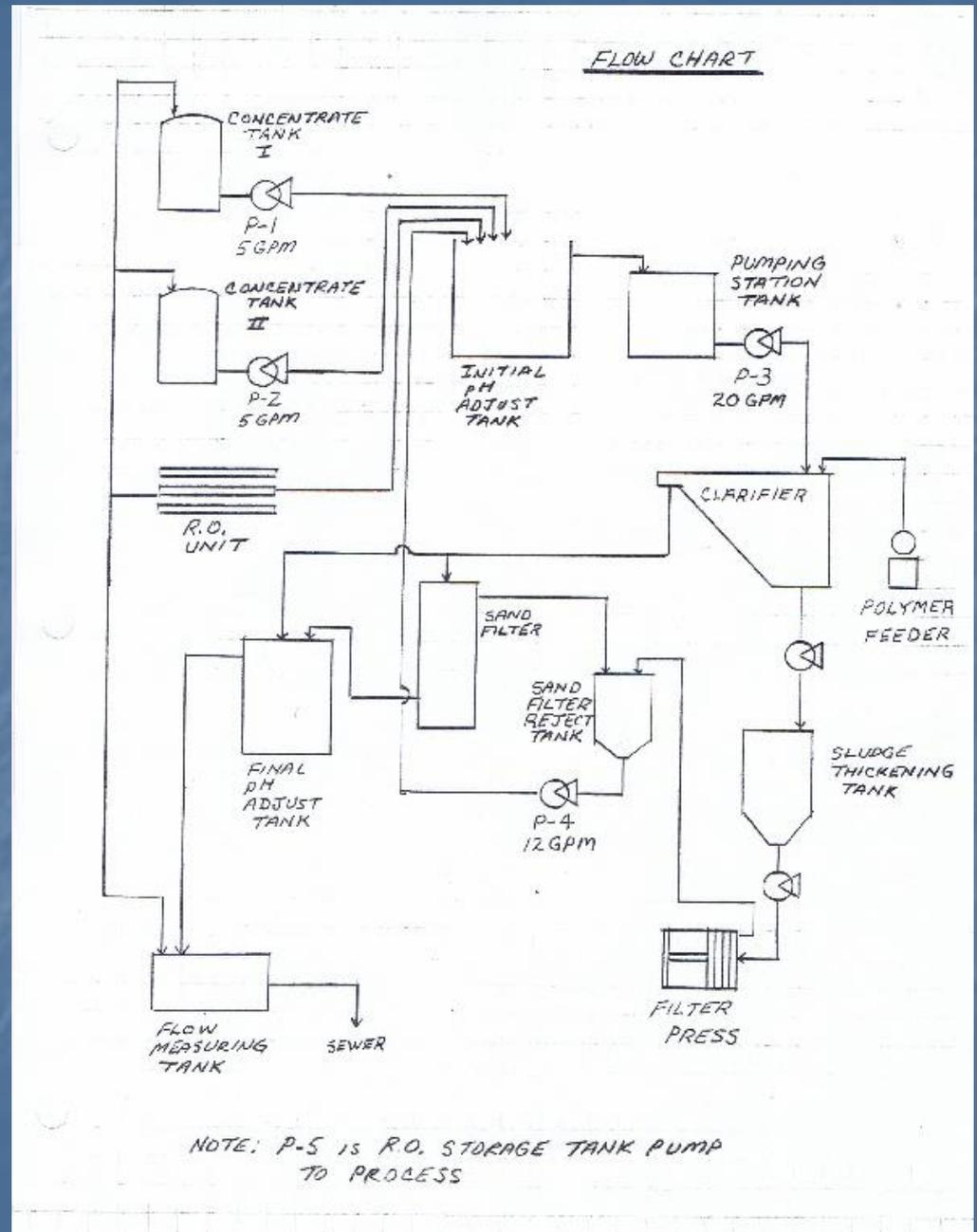



## Water Treatment System

- AIR DIAPHRAGM PUMPS  
CAST IRON
- SAND FILTER
- 1/2 H.P. GEAR DRIVE  
MIXERS 230/460V, 3 PH 60  
HZ
- STEEL MEZANINE (Heavy  
Duty)



## Water Treatment System

- LANCO MODEL 40 GPM CLARIFIER MIXER
- POLYMER FEED SYSTEM
- LANCO MODEL #2-.5/2M FILTER PRESS

# Water Treatment System

---

|                        |                       |        |      |
|------------------------|-----------------------|--------|------|
| R.O. STORAGE TANK      | 142" DIA BY 168" TALL | 10,500 | GALS |
| CONCENTRATE TANK I     | 90" DIA BY 127" TALL  | 3150   | GALS |
| CONCENTRATE TANK II    | 90" DIA BY 127" TALL  | 3150   | GALS |
| INITIAL ph ADJUST TANK | 48" DIA BY 72" TALL   | 550    | GALS |
| PUMPING STATION TANK   | 52" DIA BY 60" TALL   | 500    | GALS |
| SLUDGE THICKENING TANK | 31" DIA BY 65" TALL   | 200    | GALS |
| SANDFILTER REJECT TANK | 30" DIA BY 36" TALL   | 100    | GALS |
| FINAL ph ADJUST TANK   | 48" DIA BY 84" TALL   | 650    | GALS |
| FLOW MEASURING TANK    | 24" X 48" X 30" DEEP  | 150    | GALS |
| R.O. FEED TANK W/COVER | 60" DIA BY 66" TALL   | 800    | GALS |

# Additional Support Equipment

- Central Vacuum for Paint System
- 2 Units



# PhosPro Clean N Coat Equipment

- Clean
- Phosphatize
- Rinse & Seal
- Industrial quality metals cleaning and pretreatment
- A stationary spray wand system

# Steelman Burnoff Oven and assorted Material Handling Racks



# Gas Tank

- 12,000 Water Gallons
- 82.5" Diameter By 561" Long
- Master Tank Welding – Dallas, TX
- Design Pressure 250
- Dot Specification MC-331